

REVISIONS		
REV	DESCRIPTION	DATE

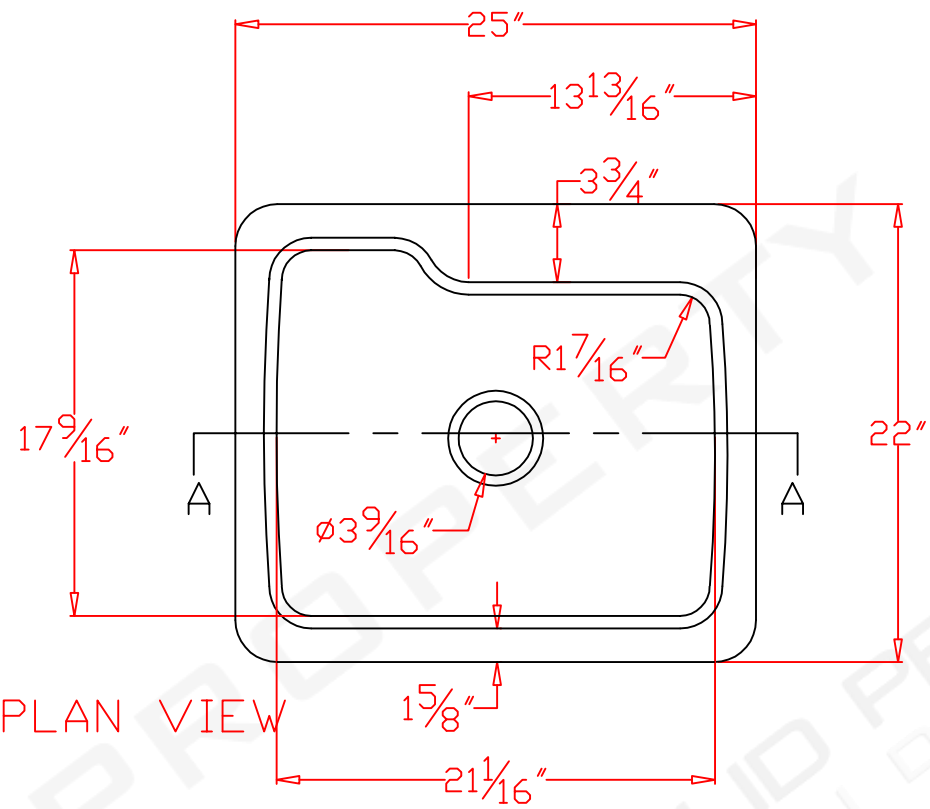

PLAN VIEW

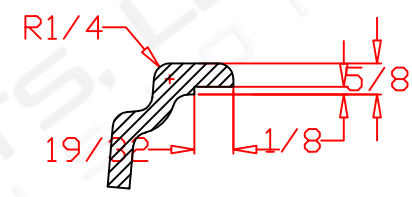

DETAIL 1

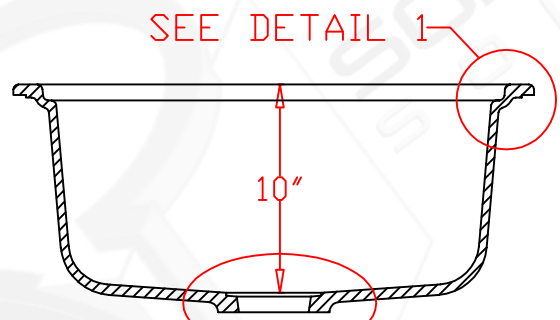

SEE DETAIL 2 CROSS SECTION A-A

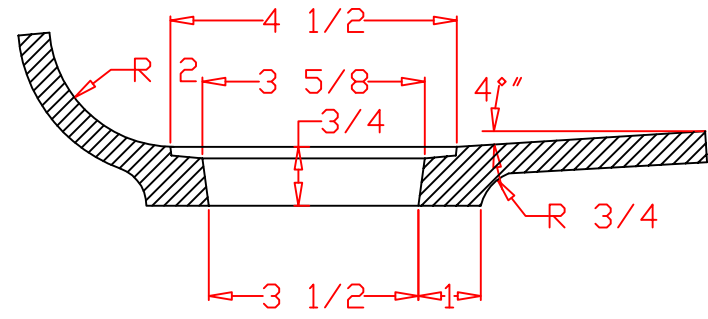

DETAIL 2

DESCRIPTION	25" x 22" Topmount Sink	
	CODE	
	PROJECT	
	LOCATION	
	COLOR	

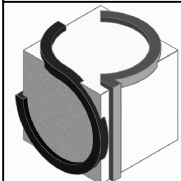

SOLID PRODUCTS, LLC
SOLID DECISION